

Uniclass	EPIC
CI/SfB	(52.4)

October 2009

**HOW TO DEAL WITH**

# grease, sediment and oil



A privately owned UK company with more than forty-five years' experience in the industry, Wade is established as a leading manufacturer of quality drainage products

Much of the success of the Company is attributable to an ongoing commitment to put technology to practical use, to generate fresh ideas, and to guarantee quality assured production.

Meeting demands of water and municipal authorities, environmentalists, employers and employees, Wade provides effective and easy to use means of dealing with grease, oil and sediment.

# Actimatic Grease Converter

### **Why use a Wade Actimatic Grease Converter?**

Grease flushed down the drain can cause blockages and unpleasant smells in work areas. Blockages can lead to overflows and health hazards, whilst drain clearing is an inconvenient and costly operation.

A Wade Actimatic Grease Converter eliminates such problems and is a **Natural** means of **Permanently** converting grease to bio-degradable products.

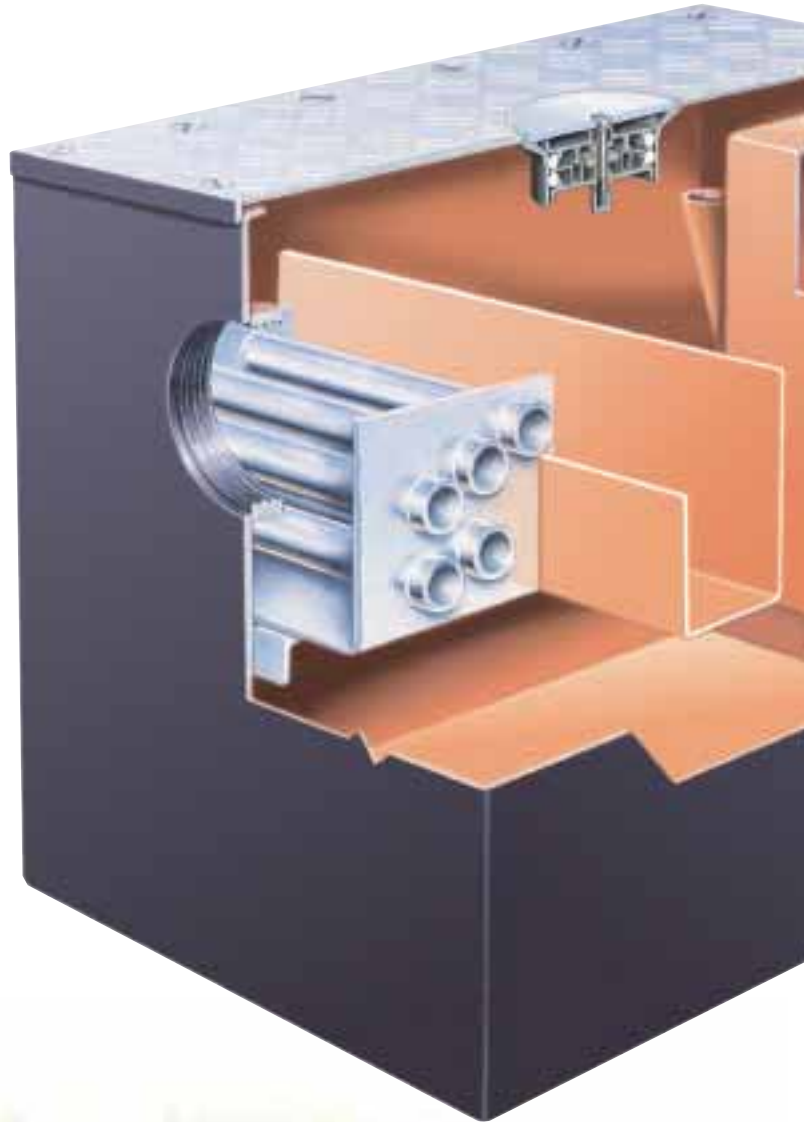

*'Use of an Actimatic Grease Converter is far more acceptable than chemicals or detergents which merely move grease downstream to become a problem for someone else.'*

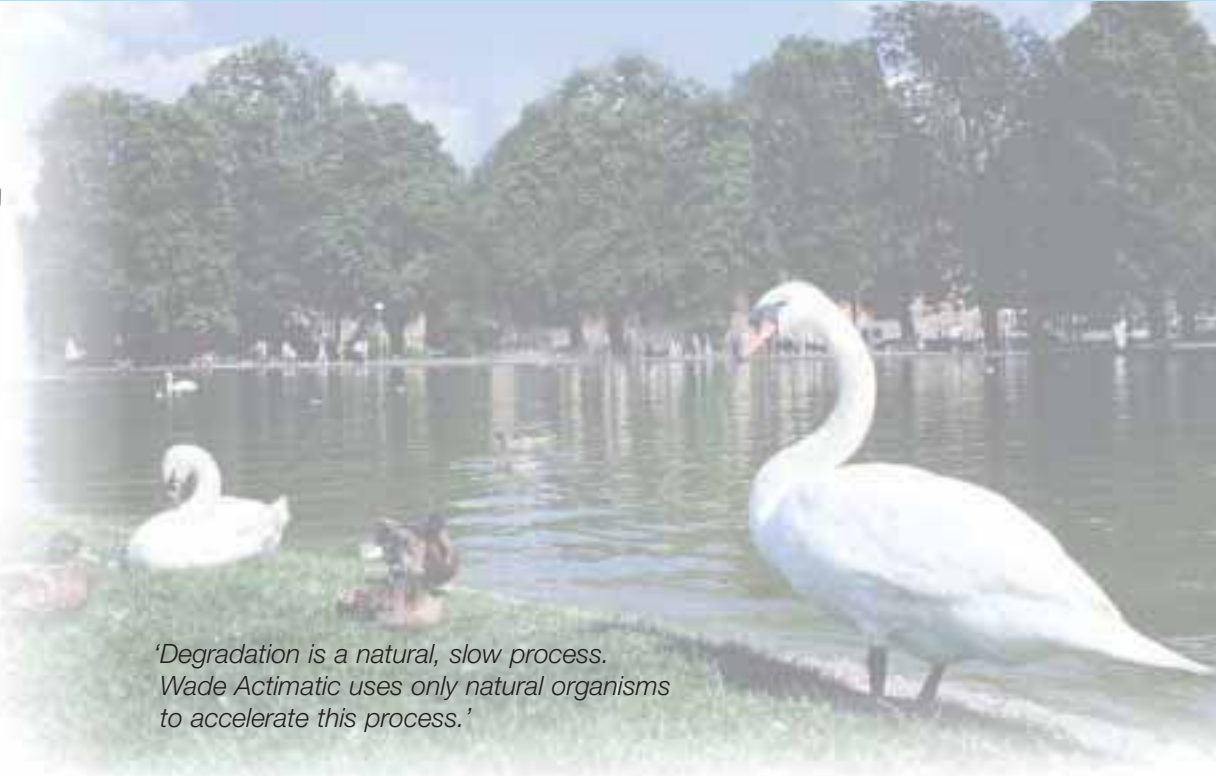

*'Degradation is a natural, slow process. Wade Actimatic uses only natural organisms to accelerate this process.'*

**Some typical locations where Wade Grease Converters are installed.**



Oil Rig, North Sea



Asda Store, Runcorn

## How does it work?

The Actimatic Grease Converter works in two stages:

1. **Separation**  
– effluent entering the converter passes over a hydrafilter baffle\* which causes grease to form in globules which float to the surface.
2. **Digestion**  
– achieved by Wade Actimatic which produces a colony of micro-organisms to degrade wastes and convert to water soluble, environmentally friendly products.



A McDonalds Restaurant



Stock Exchange, London

### Quality assurance

Certification of compliance with BS EN ISO 9001 underlines our commitment to quality and service.

\*Patent No. 13287055

## Types of installation

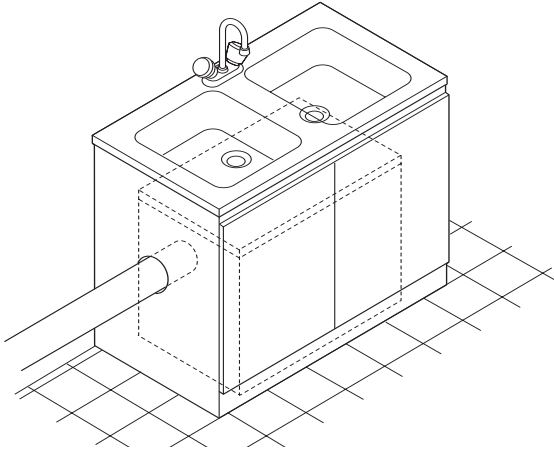

**Floor standing**  
(Standard and low profile models)

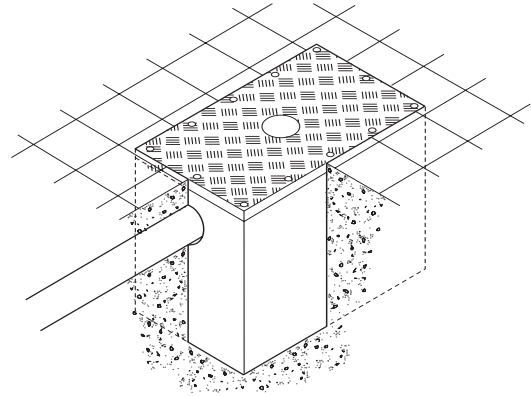

**Fully recessed in ground floor**  
(Standard invert models)

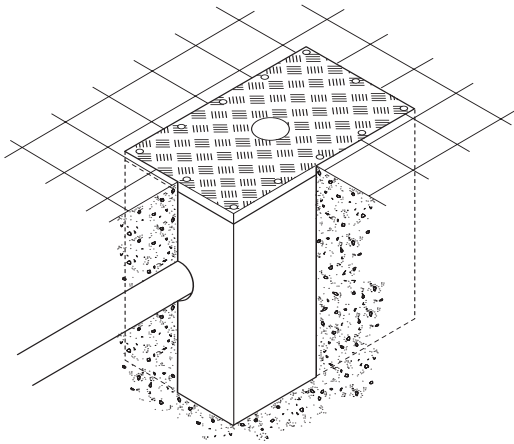

**Fully recessed in ground floor**  
(Deep invert model)

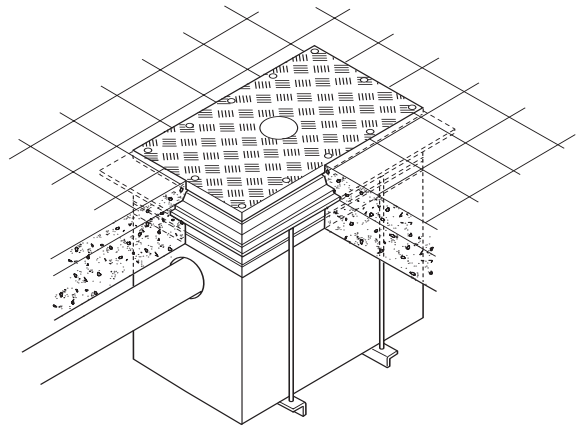

**Fully recessed in intermediate floor**  
(Hanger type)

## Installation guidelines

Wade Actimatic Grease Converters are designed to be installed in existing or new kitchens, at restaurants, canteens, hotels, hospitals, etc., and also at commercial or industrial premises where food is cooked, prepared or processed. They are not suitable for use with dedicated chicken rotisserie ovens unless special housekeeping measures are taken, including the introduction of water.

There is no optimum distance between the last fixture and the converter; it is generally accepted that pipework longer than 8 metres may allow grease to solidify before it reaches the converter.

It is not recommended that waste disposal units discharge into a Grease Converter, because frequent cleaning out will be necessary.

Waste from vegetable peelers must be filtered before discharging.

Certain cleaning agents (Chlorine, strong caustics, bleach etc.) in concentrated form, have a detrimental effect, and should not be discharged into a Grease Converter.

Installations may require prior approval from the Local Authority Environmental Health Department.

Wade Actimatic Grease Converters satisfy current Building Regulations / Standards in the U.K., and meet requirements of drainage systems designed in accordance with BS EN 12056-1:2000.

Spigot adaptors for connecting to different types and sizes of pipework are shown on page 8.

**Note: Do not reduce the stated inlet or outlet size otherwise blockages could occur.**

## How to select and size Grease Converters

To determine the optimum size of converter to be used, account must be taken of the volume of fixtures discharging into the converter. Use the table below to calculate total volume by entering the quantity of each fixture, multiply by the volume shown and enter as Total Vol.; finally, add up your answers.

Type of fixture	Approx. size (mm)	Approx. vol. (litres)	Quantity	Total vol. (litres)
Handwash sink	300 dia. x 180 deep	12		
Domestic single sink	450 x 350 x 200	32		
Domestic double sink	(450 x 350 x 200) x 2	64		
Commercial sink	600 x 450 x 300	81		
Double commercial sink	(600 x 450 x 300) x 2	162		
Commercial potwash sink	760 x 500 x 380	144		
Tilting kettle		150		
Small dishwasher	Outlet pipe 32 dia.	185		
Medium dishwasher	Outlet pipe 40 dia.	235		
Large dishwasher	Outlet pipe 50 dia.	350		
Other fixtures				
<b>Total volume of fixtures (litres)</b>				

### 5000 Series

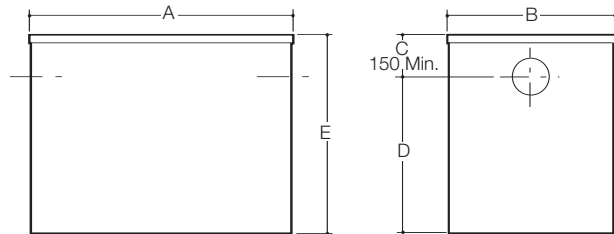

### 5200 Series

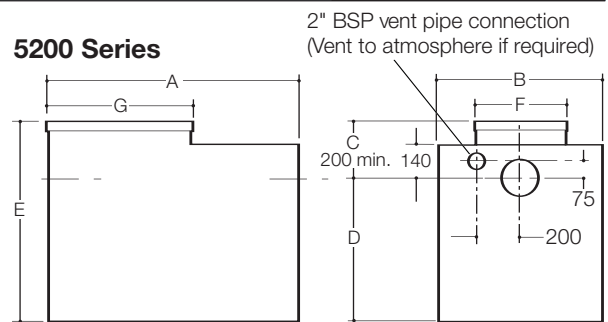

After selecting the appropriate TYPE of INSTALLATION, and calculating the TOTAL VOLUME of FIXTURES, select the 'Spec.Code' from the table below and add the required 'C' dimension to nearest 10mm. e.g. for Converter to serve fixtures with a total volume of 325 litres and having a 'C' dimension of 400mm, Specify: 5060XT 'C' = 400mm. For details of materials, accessories and alternative covers, refer to page 8.

Type of installation	Max. total vol. of fixtures in litres	Spec. code	In/Outlet B.S.P. inches	A mm	B mm	C mm	D mm	E mm	F mm	G mm	Req. slab opening	Load class
<b>Floor standing</b> Low profile	160	5020LR	4	775	482	150	180	330	●	●	●	A15
	160	5022LR	2	775	482	150	180	330	●	●	●	A15
	290	5032LR	2	988	669	150	180	330	●	●	●	A15
	290	5035LR	4	988	669	150	180	330	●	●	●	A15
<b>Floor standing</b> Standard invert	210	5030	4	594	382	150	368	518	●	●	●	A15
	410	5060	4	775	482	150	432	582	●	●	●	A15
	625	5080	4	988	669	150	419	569	●	●	●	A15
<b>Fully recessed ground floor</b> Deep invert	210	5030XT	4	594	382	To be specified on order	368	●	●	●	●	A15
	410	5060XT	4	775	482		432	●	●	●	●	A15
	625	5080XT	4	988	669		419	●	●	●	●	A15
<b>Fully recessed ground floor</b> Deep invert Large capacity	1250	5215	6	1516	953	To be specified on order	737	●	482	775	●	D400
	2100	5225	6	1869	1142		940	●	482	775	●	D400
	2900	5235	6	1996	1270		990	●	482	775	●	D400
	4200	5250	6	2315	1512		1346	●	482	775	●	D400
<b>Fully recessed intermediate floor</b> Hanger type	210	5030H	4	594	382	To be specified on order	368	●	●	●	625 x 445	A15
	410	5060H	4	775	482		432	●	●	●	805 x 545	A15
	625	5080H	4	988	669		419	●	●	●	1020 x 730	A15

For the hanger types listed, the dimension from finished floor level to the underside of the hanger frame (normally slab level) is adjustable on site from 35mm minimum to 75mm maximum.

N.B. In practice fixtures do not all discharge at the full rate simultaneously. This has been allowed for and the table enables the correct grease converter to be selected. In abnormally high or 'dump' situations contact our Technical Services Department.

## Wade Actimatic Powder and Liquid

Wade Actimatic is a bacterial product specifically formulated to deal with kitchen effluent. It is available in powder or liquid form.

Actimatic Powder is a free flowing, buff coloured, granular powder; Actimatic Liquid is a green coloured, water-soluble liquid which is suitable for manual and automatic dosing. For technical information refer to back cover.

To function efficiently grease converters must be dosed regularly with Wade Actimatic. Daily dosing is recommended, but where this is impracticable, dosing twice weekly is an acceptable minimum.

When a converter is first put into service, and whenever it is cleaned out, a culture must be established or re-established within the converter per the Initial Dosing Procedure.

The best time for dosing is just before closing down for the night; this is because the micro-biological activity is more effective when there is least flow through the converter.

Details of automatic dosing are given on page 7.

### Initial dosing procedure

(1–3 days after kitchen commences operation)

#### Actimatic Powder

- 
- Day 1
- Mix 8 level scoops (280 gm) with 2.25 litres (4 pints) of lukewarm water (30°C); stir to form a slurry.
  - Remove the dosing plug from the converter and pour in the slurry.
  - Wipe up any spillage and replace the dosing plug.
  - Wait at least 4 hours before allowing any discharge into the converter – this waiting time enables the micro-organisms to grow and reproduce in an ideal environment.

Day 2 Repeat as for Day 1.

Day 3 Commence daily dosing.

#### Actimatic Liquid

Day 1 Remove the dosing plug from the converter and pour in TWICE the amount shown in the Dosage Rate Guide.

Day 2-7 Repeat as for Day 1

Day 8 Commence daily dosing.

### Daily dosing procedure

#### Actimatic Powder

- Mix the amount of powder shown in the Dosage Rate Guide with a little lukewarm water (30°C).
- Remove the dosing plug from the converter and pour in the solution.
- Wipe up any spillage and replace the dosing plug.

#### Actimatic Liquid

Remove the dosing plug and pour in the amount shown in the Dosage Rate Guide.



### Remote dosing

As an alternative to using the dosing plug facility, Actimatic may be poured into a sink which empties into the converter, and flushed with lukewarm (not hot) water.

### Dosage rate

The amount of Actimatic needed depends on the converter model and the type and number of meals prepared. If there is a build-up of grease, increase the dosage, if there is little indication of grease, reduce the dosage. Actimatic is highly concentrated; overdosing is wasteful but not harmful.

### Daily dosage rate guide (with monthly equivalents)

Converter Model No.	POWDER		LIQUID	
	Daily level scoop	Monthly Kg	Daily capfuls	Monthly litres
5020LR	1	1	3	1
5022LR	1	1	3	1
5030	1	1	3	1
5032LR	1.5	1.5	4	1
5035LR	1.5	1.5	4	1
5060	1.5	1.5	4	1
5080	2	2	5	2
5215	2	2	6	2
5225	2	2	6	2
5235	3	3	8	3
5250	4	4	10	3

**Note: If dosing twice weekly instead of daily, use three times the rate shown.**

### To Specify / Order:

Spec. Code: **AL1** Actimatic Liquid (1 ltr.)  
 Spec. Code: **AP1** Actimatic Powder (1 kg)

Discount applies to standing orders.

## Automatic dosing system

A mains powered dispenser unit is available for use with Actimatic Liquid. The unit automatically doses the Converter with diluted Actimatic Liquid once daily at a time selected by the user.

The system, once set, requires only monthly attention to replenish the liquid supply, and is suitable for use in most new and existing drainage systems. A warning light and an audible alarm indicates low level of liquid.

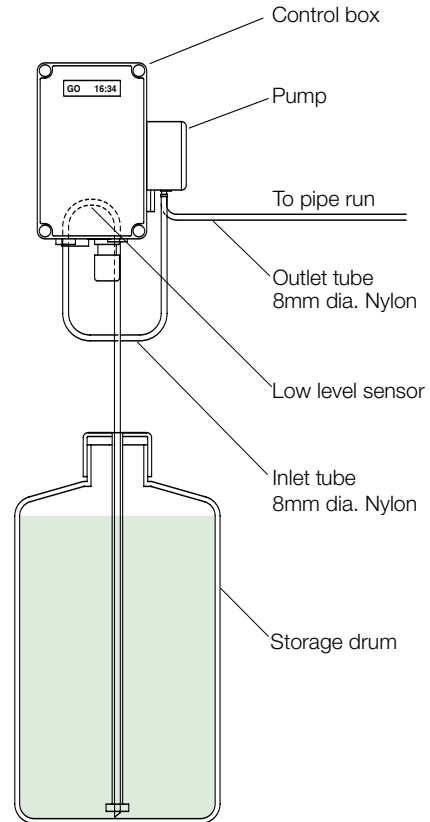
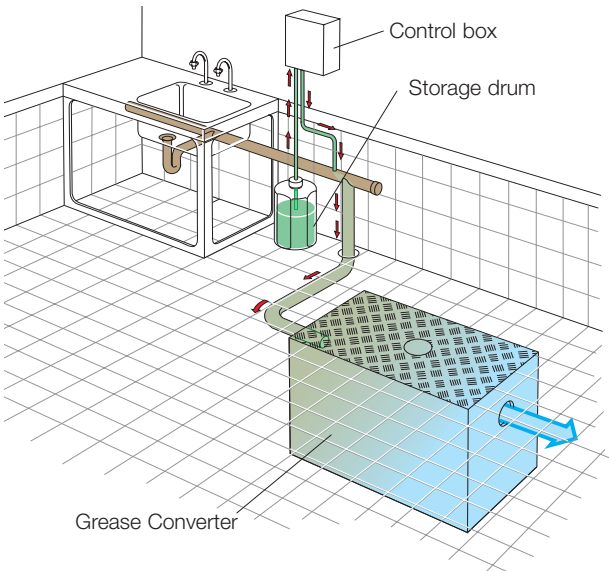

### Automatic dosing system installation notes

**Control box** – should be wall mounted.

**Electrical** – 220–240V, (Fuse rating 3 amp – internally protected by 1.6 amp fuse). 50–60Hz single phase supply must be continuous and connected to control box via an isolator by a QUALIFIED ELECTRICIAN.

**Plumbing** – ensure control box and storage drum are in final operating positions.

**Inlet** – connect nylon tube to pump by pushing tube into INLET fitting. Feed other end of tube through hole in cap of storage drum until it reaches the bottom of drum (tube may be cut to length if desired).

**Outlet** – connect nylon tube to pump by pushing tube into OUTLET fitting. For connection to pipework up to 50mm dia., use quick fit adjustable pipe connector supplied. If connecting to pipework above 50mm dia., drill and tap a 1/8" B.S.P. hole in a suitable pipe run leading to the grease converter. This hole MUST be located after the last trap in the run and in the top of the pipe if the run is horizontal. Screw and seal the supplied 1/8" B.S.P. fitting into the tapped hole. Connect free end of tube by pushing into fitting. (Tube may be cut to length if desired).

Audible alarm may be easily disabled if not required.

### Timer programming

Dosing time must be set by following the instructions supplied. Optimum start time is 2 hours after kitchen closes.

### Start-up operation

1. Read Health and Safety notes printed on the 1 litre jerrycan containing Actimatic Liquid.
2. Fill storage drum with water to level indicated on drum label.
3. Add 1 litre of Actimatic Liquid. Larger grease converters require an additional amount – refer to drum label.
4. Replace cap on drum and ensure that tube reaches the bottom of the drum.

### Construction

**Control box enclosure** – suitable for wall mounting; made of flame retardant polystyrene with removable cover, sealed to IP56. Size 180mm x 110mm x 90mm deep.

**Fixings** – stainless steel grade 304 minimum.

**Pump** – peristaltic type delivering 110 ml of liquid per minute.

**Storage Drum** – 10 ltr. capacity made of high density polythene; with screw cap and carrying handle; octagonal, 229mm across corners x 381mm high.

**Switches** – push-button, sealed to IP56.

**Timer** – programmable by user; 'Mains On' and 'Low Liquid Level' indicators; rechargeable back-up battery (maintains the timer programme, it will not run the pump).

**Tubing** – 8mm dia. clear nylon or equivalent.

### Maintenance

1. 30 days after start-up and every 30 days thereafter, re-fill storage drum with water and Actimatic Liquid.
2. Every 30 days check fittings and tubes for leaks.
3. Every 6 months check pump tubing for signs of wear.

### To Specify / Order:

Spec. Code: **ADU** Automatic Dosing Unit

Spec. Code: **AL1** Actimatic Liquid (1 ltr.)

Options: Wall mounting bracket for storage drum – made of grade 304 stainless steel with large radiussed corners to facilitate cleaning – add suffix 'MB' to Spec. Code.

**Accessories**

**Decorative housing – stainless steel**

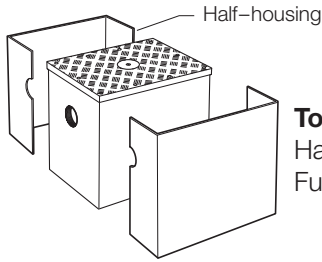

**To Specify / Order**  
 Half housing – suffix 'D'  
 Full housing – suffix 'D2'

**Spigot adaptors – to connect converter to pipework**

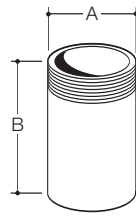

Spec. code	Pipework	A	B
T103	BS 416 / DIN 19522	100	90
T104	BS 416 / DIN 19522	150	90
T105	BS 437	100	90
T106	BS 437	150	90
T1704	Plastic	110	126
T303	Plastic	160	166
T401	Clay (Densleve)	100	170
T402		150	105
T501	Clay (Supersleve)	100	130
T502		150	130

**Covers** – for alternative covers, add suffix to Spec.Code as follows:  
 Heavy Duty (class D400) – mild steel, painted – **'HD'**  
 Recessed (min.'C' dimension = 170) – stainless steel – **'REC'**  
 For use with sheet floor covering (min.'C' dimension = 180)  
 – stainless steel frame – **'SVF'**

**Maintenance**

**Commissioning period maintenance**

During the first few weeks of dosing operation, regular inspection of the internal condition of the Converter should be made to gauge the performance of the dosage amount. If a thickening of the contents is noted, with a distinct caking effect across the surface, or an offensive, pungent odour is emitted, then gradually increase the suggested dosage rate to compensate. If the contents appear to remain in a minimal semi-liquid state with little or no odour, this indicates successful degradation of the grease.

**Grease converter performance**

The Converter is working if there is:

- (a) Consistency similar to thick soup.
- (b) Little or no odour.
- (c) No dry deposit building up on its sides.
- (d) No caked deposit floating on surface.
- (e) No grease build-up in downstream drain line.

**Routine maintenance**

Operation	Frequency
Remove main cover Remove and clean Hydrafiliter baffle Check contents for caking Check for sediment build-up. If build-up has occurred tank should be cleaned	Quarterly
Remove main cover Remove and clean Hydrafiliter baffle Clean out tank completely Check for paintwork deterioration and treat as required Check joints and seal	Annually

Whenever tank is cleaned out the Initial Dosing procedure must be repeated. Sediment build-up can be reduced if strainers are fitted to sinks to prevent solids entering the Converter.

**For best performance**

1. Follow the Initial and Daily Dosing Procedures.
2. Do not discharge very hot water into the Converter immediately before or immediately after dosing.
3. Do not discharge chlorine, strong caustics, concentrated disinfectants, bleach or sanitisers into the Converter.
4. Do not deliberately discharge cooking oil or grease into the Converter.
5. Remember that food scraps and solid particles will settle on the bottom of the Converter and will need to be removed periodically. Do not discharge waste disposal units into the Converter.
6. Follow maintenance procedures.
7. Contact Wade Technical Services Department if you need advice; a free call out service is provided in mainland U.K. for regular users of Actimatic.

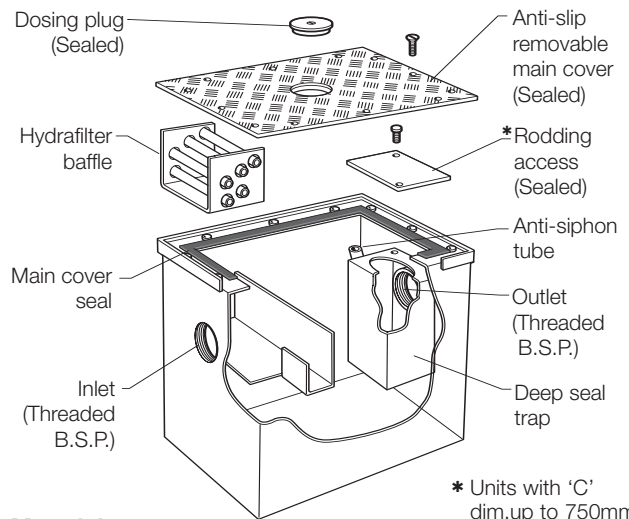

\* Units with 'C' dim.up to 750mm

**Materials**

Cover and dosing plug assembly – aluminium<sup>†</sup>  
 Fixings and trim – stainless steel grade  
 Seal – expanded closed cell neoprene  
 Other parts – mild steel, painted.<sup>††</sup>

<sup>†</sup>**Note:** 5200 series models have painted mild steel covers with no dosing plug or rodding access.

<sup>††</sup>*Stainless steel version also available, please contact our Technical Services Department for details.*

# Sediment Interceptors



Sediment Interceptors are used to help prevent blockages where solids such as food scraps, hair, plaster, sediment etc. are discharged into drain lines.

## How does it work?

Solid material is captured in a collector – a bucket or, for fine particles, a filter bag – which needs to be lifted out of the interceptor for emptying at an appropriate frequency.

### Features

- suitable for floor standing or semi-recessed installations
- 2" B.S.P. female inlet and outlet may be connected to pipework by means of proprietary connectors

### Material

Stainless steel

Seal – expanded closed cell neoprene.

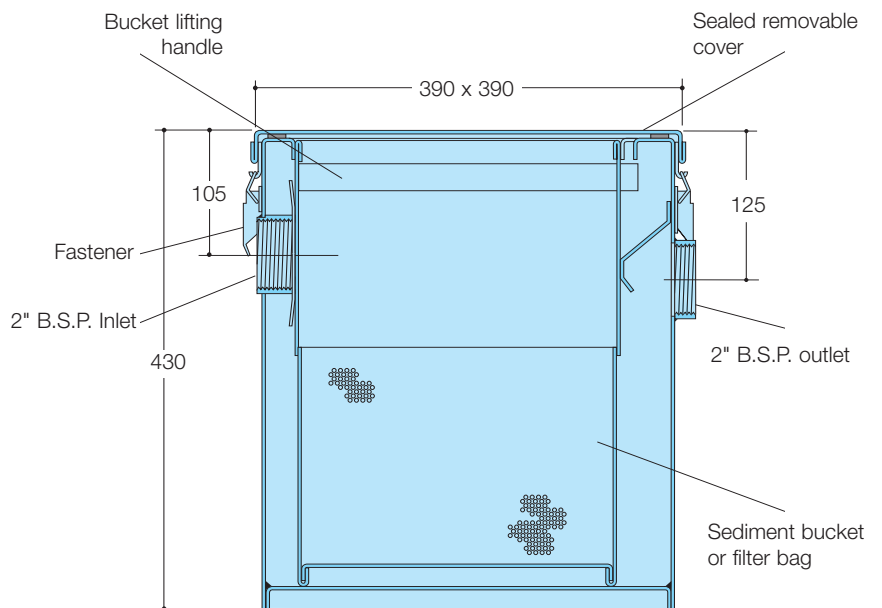

### Routine maintenance

Operation	Frequency
Remove main cover	Annually
Remove and clean collector	
Drain and clean tank	
Check joints and seal	

Spec. code	Flow rate l / sec.	Solids collector
5740	0.4	Bucket – stainless steel
5750	0.4	Bag – polyester

**Note: Minimum clearance above cover of 450mm is required for removal of bucket / bag**

# Oil Interceptors

Oil Interceptors are installed in drain lines to help prevent the pollution of rivers, streams, drainage systems and water treatment plants.

Units are used where spillages of oil or diesel could occur such as garages, transport workshops, diesel re-fuelling and storage areas, and where vehicles or plant are washed down or steam cleaned.

Oil Interceptors are not suitable for petrol and volatile liquids.

## How does it work?

The Wade trapped Oil Interceptor works in three stages.

### 1. Separation

Effluent entering the Interceptor passes through a filter bucket which retains solid material; oil, being lighter than water, floats to the surface, pending draw-off.

### 2. Removal of oil

By automatic or manual means, oil flows through an adjustable draw-off point to a sump or a similar storage container awaiting disposal.

### 3. Removal of solids

The bucket which retains solid material needs to be lifted out of the Interceptor for emptying at an appropriate frequency.

## Features

- suitable for floor standing or recessed installations.
- vent and draw-off connections are provided on both sides of the Interceptor for ease of installation and use.
- draw-off points located inside the Interceptor are adjustable by the user (see drawing and notes on page 11).
- loading class: D400.
- recessed covers can be made to special order.
- threaded inlet and outlet are for connection to pipework by means of a spigot adaptor, shown on page 8.

## Materials

Bucket and fixings – *stainless steel*  
 Seal – *expanded closed cell neoprene*  
 Other parts – *mild steel*.

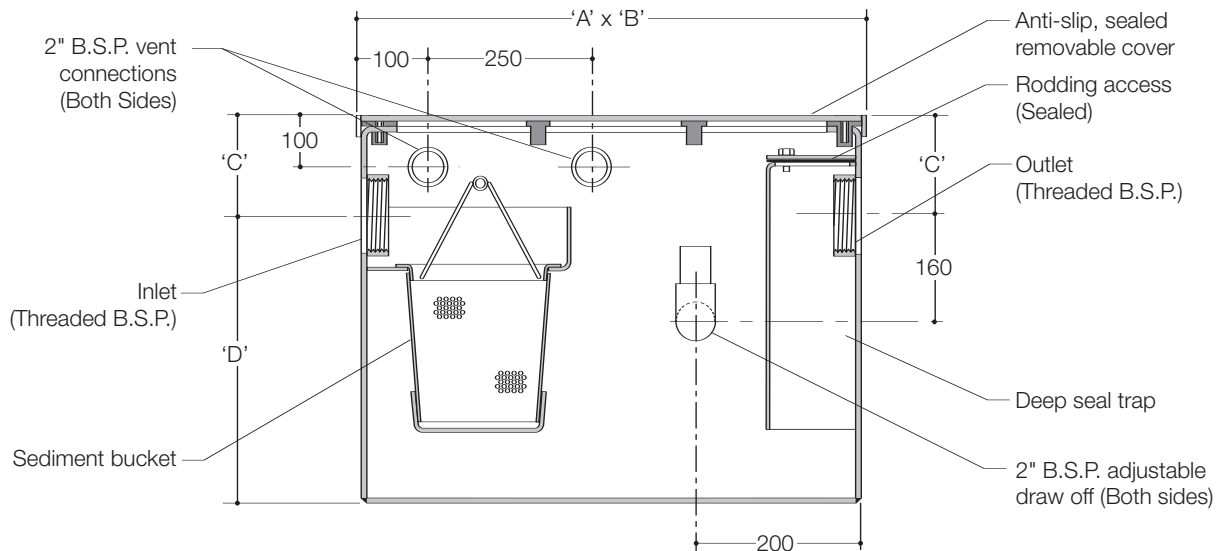

## To Specify / Order

Select the appropriate code from the table and add the required 'C' dimension, e.g. for oil interceptor to accept a flow 3.5 l/sec. and having a 'C' dimension of 250mm. – Specify 5360, 'C' dimension = 250mm.

Spec. code	Flow rate l/sec	Inlet / Outlet size B.S.P.	A	B	C	D
5330	1.9	4"	594	382	To be	368
5360	3.8	4"	775	482	Specified	432
5380	5.7	4"	988	669	on order *	419

### Note:

**\*Minimum 'C' dimension available is 150mm, larger dimensions should be specified in increments of 10mm. Larger sizes of oil interceptors are available, please contact our Technical Services Department for details.**

## Installation

### Notes:

1. 2" B.S.P. Vent and draw-off connections are provided on both sides of the interceptor for ease of installation.
2. All connection points not used must be sealed.
3. Ensure location of interceptor enables easy access to draw-off valve and cover.

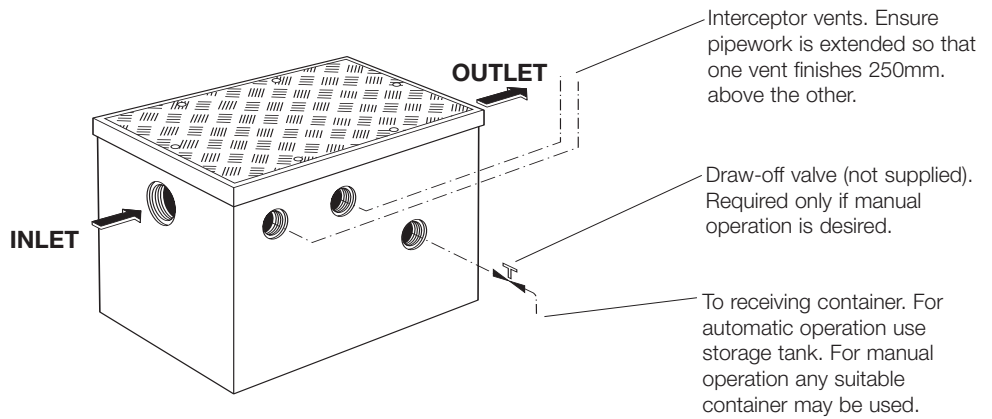

### Settings of adjustable draw-off

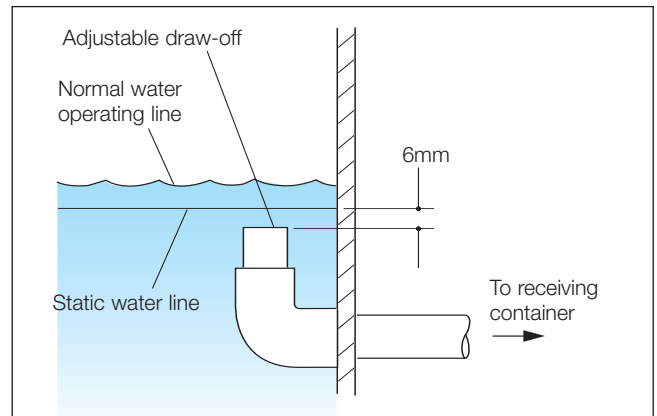
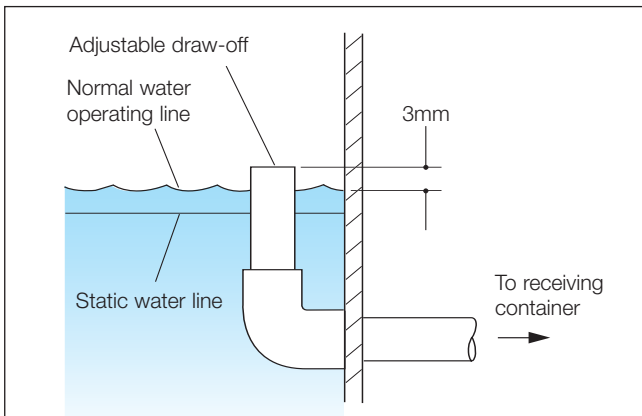

#### Setting A

##### Ensures that only oil is taken from interceptor

Normally used in automatic installations with drawn-off oil collecting in storage tank. This setting will retain a layer of oil in the interceptor.

##### Checking operation

If during normal working conditions water is found to be entering the draw-off line, the following action should be taken;

For manual and automatic operations:

Adjust draw-off upward by 3mm. Check operation, repeat if required.

#### Setting B

##### Ensures that ALL oil is removed from interceptor

Normally used with manual draw-off installations. This setting will allow water to enter the draw-off line.

##### Checking operation

If during normal working conditions oil is found to be remaining in interceptor, the following action should be taken;

Manual installations: Draw-off oil more frequently and/or lower draw-off by 3mm. Check operation and repeat if required.

Automatic installations: Lower adjustable draw-off by 3mm. Check operation, repeat if required.

## Maintenance

### Commissioning period maintenance

#### Manual draw-off

During the first 4 weeks of operation, regular inspection of the internal condition of the interceptor should be made to determine how often the oil needs to be drained off and the sediment bucket emptied.

#### Automatic draw-off

During the first 4 weeks of operation check the oil storage tank for build-up, and the sediment bucket to determine how often it needs to be emptied.

### Routine Maintenance

Operation	Frequency
MANUAL – Remove main cover Drain off oil Remove and clean sediment bucket AUTOMATIC – Remove main cover Remove and clean sediment bucket	As indicated by inspection during commissioning period.
BOTH TYPES – Remove main cover Remove and clean sediment bucket Drain and clean tank completely Check for paintwork deterioration, and treat as required Check joints and seal	Annually

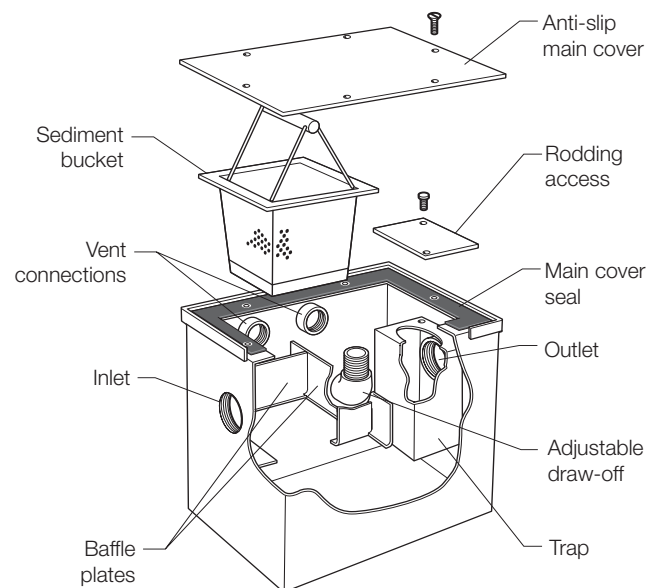

## **Wade Actimatic – supplementary information**

Wade Actimatic is a mixture of micro-organisms, free enzymes, inorganic salts, buffers and non-ionic surfactants.

Six strains of micro-organism are selected because of their ability to produce the enzymes required to break down the range of waste materials produced by the catering industry. The micro-organism population comprises a range of bacilli, micrococcus and streptomycete cultures.

Four main types of enzymes are produced by the micro-organisms which operate in Wade Actimatic:

- Lipases – to break down fats and grease
- Amylases – to break down starch
- Proteases – to break down protein
- Cellulase – to break down cellulose

Enzymes serve to accelerate the establishment of the micro-biological culture; they have a limited life and will eventually be used up. Any dead micro-organisms will themselves be broken down and digested by other bacteria.

The micro-organisms in Actimatic Powder are naturally occurring and are not genetically engineered or genetically modified; they belong to Class 1 as defined in the EU Council Directive 90/679/EEC of 26th November, 1990 and as amended by EU Council Directive 93/88/EEC of 12th October, 1993.

Actimatic Powder and its intermediates are tested using procedures recommended by the USDA and AOAC to ensure that they are free of Salmonella.

**Environmental impact.** The term BOD, biological oxygen demand, is often used in association with biological breakdown. BOD is a measure of the amount of organic matter in water and waste; it is the amount of oxygen in a given volume of water, consumed by micro-organisms during the degradation of organic matter over a five day period. High BOD causes concern since the loss of soluble oxygen in the water can create anaerobic conditions, which give rise to the production of foul odours arising from the formation of sulphides (particularly H<sub>2</sub>S) and methane; these conditions inhibit the degradation of fats and grease.

Wade Actimatic will not increase the BOD of the discharge from a correctly sized grease converter, nor the BOD loading of the final effluent plant.

All the ingredients of Wade Actimatic are bio-degradable and will have no adverse effect on the downstream biological clean-up operation.

Grease is converted permanently into soluble products which will not re-deposit further down the drainage system.

Wade Actimatic, when properly used, is not harmful to people, wildlife or the environment.

## **Independent product assessment:**

In 1989 Wade became the first manufacturer of grease converters to be awarded an Agrément Certificate.

For the Grease Converter, an innovative product, there is no applicable British or European product standard. BS EN 1825 applies to products that require the physical removal of grease; the scope of the standard states "The standard does not cover the use of biological means (bacteria and enzymes)".

## **Other products**

Wade manufactures a wide range of products for use in and near all kinds of buildings, worldwide: Floor gullies, access covers, channel and grating, roof outlets, water points. Full details, including CAD files are accessible on our website

## **Service**

Product information and technical advice are available from the Wade Technical Services Department at Halstead, Essex, from Wade Technical Consultants located throughout the U.K. and from selected distributors throughout the world.

## **Warranty**

The Company warrants its products to be free from defects in material and workmanship for a period of 12 months from the date of delivery.

The Company's obligation under this warranty is limited, at its option, to the repair or replacement, free of charge, or refund of the net invoiced price of any part found to be defective, and which, in the Company's opinion, has not been subject to undue wear and tear, accident, alteration, abuse or misuse. Consequential damages are expressly disclaimed.

Technical advice from Wade International Ltd., whether verbal, in writing or by way of trials, is given in good faith but without warranty. The application, use and installation of the Company's products are beyond the control of the Company and the purchaser is solely responsible for ensuring that goods are fit for any particular purpose.

In line with the Company's policy of continual research and development, product specifications and availability are subject to change or withdrawal without prior notice.

## **Dimensions**

In line with general practice all dimensions shown are nominal.

## **Load rating class**

This catalogue shows the load rating class for covers based on BS EN 124.



QUALITY BY TRADITION  PERFORMANCE BY DESIGN

**Wade International Ltd.**

Third Avenue • HALSTEAD

Essex • CO9 2SX • U.K.

TELEPHONE: +44 (0)1787 475151 • FACSIMILE: +44 (0)1787 475579

e-mail: tech@wade.eu • web site: www.wade.eu